

	A	B	C	D	E	L
PI70-06-14DX/SX	6	14	14	22	23	120
PI70-06-16DX/SX	6	14	16	22	23	120
PI70-06-20DX/SX	6	14	20	22	23	120
	A	B	C	D	E	L
PI70-08-14DX/SX	8	16	14	22	23	120
PI70-08-16DX/SX	8	16	16	22	23	120
PI70-08-20DX/SX	8	16	20	22	23	120
	A	B	C	D	E	L
PI70-10-14DX/SX	10	16	14	22	23	120
PI70-10-16DX/SX	10	16	16	22	23	120
PI70-10-20DX/SX	10	16	20	22	23	120

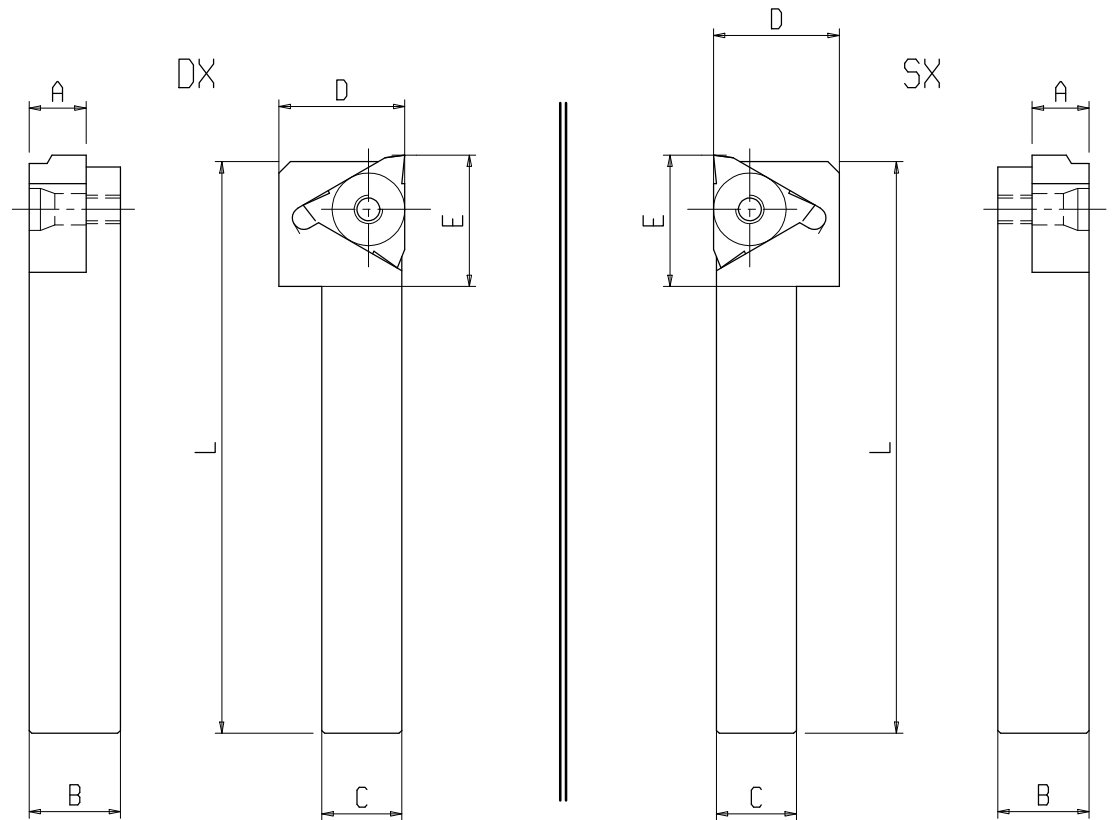

TOLLERANZE GENERALI					
Dimens. lineari mm	< 0.5	0.5-20	20-50	50-100	> 100
Tolleranza micron	± 50	± 100	± 200	± 300	± 400
Fori H13	Alberi h13	∠ ± 30' @ ± 100			
Rugosità gen.	RA 3.2				
CRM Utensili speciali					
N° Codice	PI70-TR				Modifica
	1	2	3	4	5 6